



Bendi®

B55AC

4-Wheel Heavy Capacity
Electric Multi-Purpose
Articulated Forklift Truck

STANDARD FEATURES

- 5,500 lb. (2,495kg) Capacity
- Lift Heights to 360" (9.14M) • 84" (2.13M) Stacking Aisle with 48" (1,200mm) Long Load
- High Visibility 3-Stage or 4-Stage Mast
- Integral 11.2" (285mm) Stroke Side Shifter and 36" (914mm) High Load Backrest
- Dual Inside / Outside Capability
- Articulated Floating Front Axle, 48" (1,219mm) Wide
- Large Diameter Smooth Rubber Drive Tires
- Polyurethane Load Tires
- 180° Front-End DuraSteer™ Articulation Steering Assembly with 5-Year Warranty
- Heavy Duty Dual Rear Wheel Planetary Drives
- AC Traction and Hydraulic Controllers
- Powerful AC Drive and Hydraulic Motors
- Comfortable Seated Operation with All Truck Controls in Easy Reach
- Full Diagnostic Intelligent Display with Battery Discharge Indicator and Hour Meter
- Adjustable Cloth Suspension Swivel Seat
- Armrest, Adjustable Steering Column, Key Switch, Horn and Seat Belt
- Hydraulic Power Steering
- 4-Post Heavy-Duty Overhead Guard
- Safety Deadman Seat Switch
- Heavy Duty Unitized Robotic Welded Chassis Design
- Provisions for RF Terminals Provided
- Accepts Class II Attachments
- Easily Accessible Components for Low Cost Maintenance

OPTIONAL FEATURES

- Non-Standard Fork Lengths
- LED Headlights, Flashing Light and Rear Safety Lights
- Integral Side Shifting Fork Positioner
- Auxiliary Hydraulics
- Non-Marking Tires
- UL 583, Type EE Electrical Rating, FM Approved
- Vinyl Seat
- Slide-Out Battery Tray
- Fire Extinguisher
- Lazer Fork Height Indicator
- Carriage Mounted Camera with Operator Compartment Monitor
- Capable of Freezer Operation to -22°F (-30°C)



To learn more about what Total Warehouse is doing to ensure warehouse, distribution and supply chain operations stay efficient and productive, visit www.totalwarehouse.com.

TOTAL
WAREHOUSE®

TECHNICAL DATA

MODEL			B55AC
Capacity		at 24" (600mm) Load Center	lbs/kg 5,500 / 2,495
Weight		with Battery	lbs/kg 16,950 / 7,705
Travel Speed		Loaded	mph/kph 6.5 / 10.5
		Unloaded	mph/kph 7 / 11.3
Lift Speed		Loaded	fpm/mpm 90 / 27.4
		Unloaded	fpm/mpm 110 / 33.4
Lowering Speed		Loaded	fpm/mpm 100 / 30.5
		Unloaded	fpm/mpm 90 / 27.4
Mast Tilt		Fwd / Back - Up to 293° (7.44M)	deg 3 / 3
		Fwd / Back- 294° (7.46M) to 360° (9.14M)	deg 1 / 2
Load Center	E		in/cm 12 / 310
Wheelbase	F		in/cm 69 / 175
Rear Overhang	G		in/cm 31.7 / 81
Overall Length Fork to Face	H	Mast Vertical	in/cm 113 / 287
Underclearance	I		in/cm 3 / 7.6
Operator Floor Height	J		in/cm 31 / 79
Overhead Guard Height	K		in/cm 89 / 226
Overhead Guard Width	L		in/cm 46 / 117
Overall Width	M		in/cm 56 / 142
Fork Carriage Width	N		in/cm 41 / 104
Fork Length	O		in/cm 40 / 101
Out to Out Fork Spread	P	Minimum/Maximum	in/cm 9.4-39.5 / 24-100
Battery Compartment Height	Q	Floor to Top of Battery Tray	in/cm 19 / 48
Right Angle Stacking Aisle		with 48"L x 40"W (1200mm x 1000mm) Load	in/cm 84 / 213
Intersecting Aisle		with 48"L x 40"W (1200mm x 1000mm) Load	in/cm 114 / 289
Gradeability		Loaded / Unloaded	% 15 / 15
Hydraulic Motor Rating		Continuous Duty Rating	type/kWh AC / 16.8
Traction Motor Rating		Continuous Duty Rating	type/kWh AC / 7.5 ea - 15 Total
Traction Control Type		Induction	AC
Hydraulic Control Type		Induction	AC
Wheel Sizes		Front (2 Each) Poly - Dia. x Face	in/cm 14x8 / 36x20
		Rear (2 Each) Rubber - Dia. x Face	in/cm 18x9 / 46x23

B55AC

Electric Multi-Purpose VNA Articulated Forklift Truck

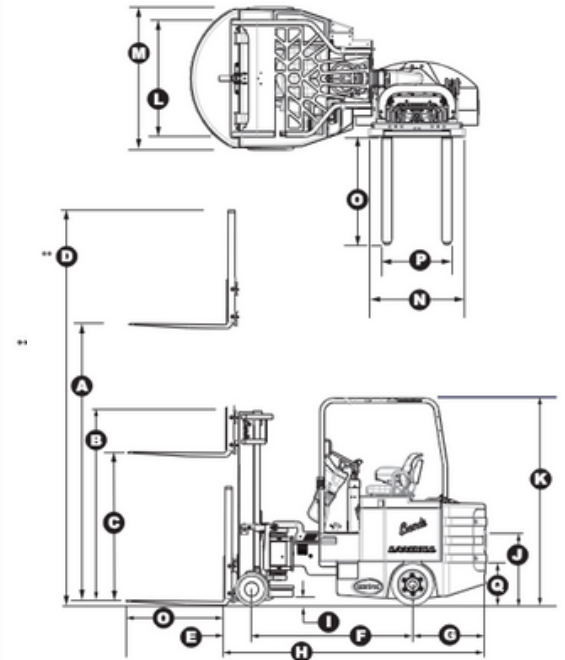

MAST DIMENSIONS

LIFT HEIGHT (A)		LOWERED HEIGHT (B)		** FREE LIFT (C)		OVERALL HEIGHT (D)	
Inches	Meters	Inches	Meters	Inches	Meters	Inches	Meters
Triple (3-Stage) Mast							
188	4.78	83	2.11	47	1.19	224	5.69
198	5.03	87	2.21	51	1.30	234	5.94
216	5.49	95	2.41	59	1.50	252	6.40
223	5.66	98	2.49	62	1.57	259	6.58
242	6.15	107	2.72	71	1.80	278	7.06
258	6.55	115	2.92	79	2.01	294	7.47
272	6.91	121	3.07	85	2.16	308	7.82
296*	7.52	129	3.28	93	2.36	332	8.43
312*	7.92	132	3.35	96	2.44	348	8.84
323*	8.20	138	3.51	102	2.59	359	9.12
360*	9.14	156	3.96	120	3.05	396	10.06
Quad (4-Stage) Mast							
250	6.35	91	2.31	55	1.40	286	7.26
260	6.60	95	2.41	59	1.50	296	7.52
276	7.01	102	2.59	66	1.68	312	7.92
295*	7.49	109	2.77	73	1.85	331	8.41
315*	8.00	117	2.97	81	2.06	351	8.92
* Tilt Restricted to 1° Forward and 2° Backward							
** Free Lift Based on 36" (914mm) High Load Backrest							

AISLE DIMENSIONS

LOAD DEPTH X WIDTH	MINIMUM CLEAR AISLE
40" x 48" (1,000 x 1,200mm)	78" (1,930mm)
48" x 40" (1,200 x 1,000mm)	84" (2,134mm)
Transfer or End Aisle	114" (2,896mm)

RECOMMENDED BATTERY

BATTERY DESIGNATION: 24-85-23, 48 VOLT, 935 AHC (6 HOUR RATE)
Nominal Size: 44.75" x 32.25" x 22.63" (114 x 82 x 58cm)
Truck Compartment Size: 44.875" x 32.5" x 23" (114x83x59cm)
Battery Weight Min: 3,500 lbs. (1,590kg) Max: 4,000 lbs. (1,818kg)
Leads are at Position A, 12" (30.5cm) Long, with SB 350 Amp Blue Connector

The specifications contained in this spec sheet are subject to change at any time without notice. Actual dimensions and performance data given herein may vary due to manufacturing tolerances.

To learn more about what Total Warehouse is doing to ensure warehouse, distribution and supply chain operations stay efficient and productive, visit www.totalwarehouse.com.

TOTAL
WAREHOUSE