

OPERATOR'S MANUAL



LPT44

POWERED PALLET TRUCK



WARNING

Do not operate this truck unless you have:

Been authorized and trained to do so.

Have read all warnings and instructions in operator manual and on this truck.

Do not operate this truck until you have:

Checked its condition. Give special attention to tires, horn, battery, controller, lift system, brakes, steering mechanism, guards and safety devices.

Operate truck only from designated operating position. Do not carry passengers. Keep feet clear of truck and wear foot protection.

Observe applicable traffic regulations. Yield right of way to pedestrians. Slow down and sound horn at cross aisles and wherever vision is obstructed.

Start, stop, travel, steer and brake smoothly. Slow down for turns and on uneven or slippery surfaces that could cause truck to slide or overturn. Use special care when traveling without load as the risk of overturn may be greater.

Always look in the direction of travel. Keep a clear view, and when load interferes with visibility, travel with load trailing.

Take special care when operating on ramps - travel slowly, and do not travel in an angle or make turns. Travel with forks facing downhill.

Do not overload truck. Check nameplate for capacity and load center information.

Do not handle loads which are higher than the load backrest or load backrest extension unless load is secured so that no part of it could fall backward. Before lifting, make sure the load is centered, forks are completely under load, and load is as far back as possible against load backrest.

When leaving the truck, neutralize travel control, fully lower the forks and set brake. When leaving truck unattended, also shut off power.

PROPOSITION 65



WARNING

In accordance to

California Health & Safety Code Sections 25249.5 et. seq.
this warning is to let you know that this product can expose
you to chemicals known to the state of California to
cause cancer, birth defects and other reproductive harm.

For more information visit: www.p65warnings.ca.gov

FOREWORD

As a lift truck operator, you are responsible for a machine that is useful, powerful, and can be hazardous if not operated as described. Your Big Lift LLC truck may weigh more than some cars, depending on the model. Observing and practicing the safety warnings in this manual cannot be overemphasized. Just knowing the warnings, however, is no substitute for common sense. Focusing on the task at hand will, in almost all cases, prevent accidents. Think of the truck as your own. In this way you will learn its capabilities and limitations.

This manual is intended to remain with the truck at all times as a handy reference guide to operation. Detailed maintenance procedures are found in the service manual for the specific truck model, and are to be performed only by a qualified technician. For further information on obtaining a complete parts and service manual, see [page 21](#) of this manual.

The operator who knows his truck will learn to spot problems as they develop. This is accomplished by performing the Daily Checks and reporting any problems to the designated authority.

TABLE OF CONTENTS

SAFETY SYMBOLS	5
GENERAL DESCRIPTION	5
NAME PLATE AND WARNING DECAL	5
LOAD CAPACITY	8
BEFORE OPERATION	9
INSTRUMENTS AND CONTROLS	12
Display Unit	12
Low Voltage Protection.....	12
OPERATION	13
Driving Instructions	13
Steering	14
Stopping.....	14
Parking	14
Load Handling	14
Moving a Disabled Truck.....	15
Battery Charging.....	15
NOTICE - OBTAINING A PARTS AND SERVICE MANUAL.....	23

SAFETY SYMBOLS

WARNING and **CAUTION** are both signal words intended to alert the viewer to the existence and relative degree of a hazard. They are both preceded by a safety alert symbol consisting of an exclamation mark enclosed by a triangle.



A **Warning** indicates a hazard which could result in injury or death if proper precautions are not taken.

A **Caution** indicates a reminder of routine safety practices.

A prohibition slash (circle with diagonal slash through it) indicates a procedure or action that should **not** be performed under any circumstances, as both personal injury and/or damage to equipment will result.



GENERAL DESCRIPTION

Big Lift LLC Pallet trucks lift and transport loads on rigid forks.

Control for steering, braking, forward and reverse travel, horn, lift, lower and speed control are all located on the control handle.

Trucks in this series may vary in load capacity, battery arrangement, and instrumentation, depending on model and options.

NAME PLATE AND WARNING DECAL

Name plate and warning decal locations may vary between models, but they are always near the steering arm within sight of the operator.

If the name plate or warning decal are lost or damaged they should be replaced immediately. Have your supervisor or the designated authority contact Big Lift LLC Authorized Dealer for replacement.

The name plate shows the model number, serial number, and truck type. Battery type, with voltage and minimum weight, is shown along with information on the load capacity and load center.

The warning decal contains warnings which also appear, with illustrations, in the Operating Precautions section of this manual.

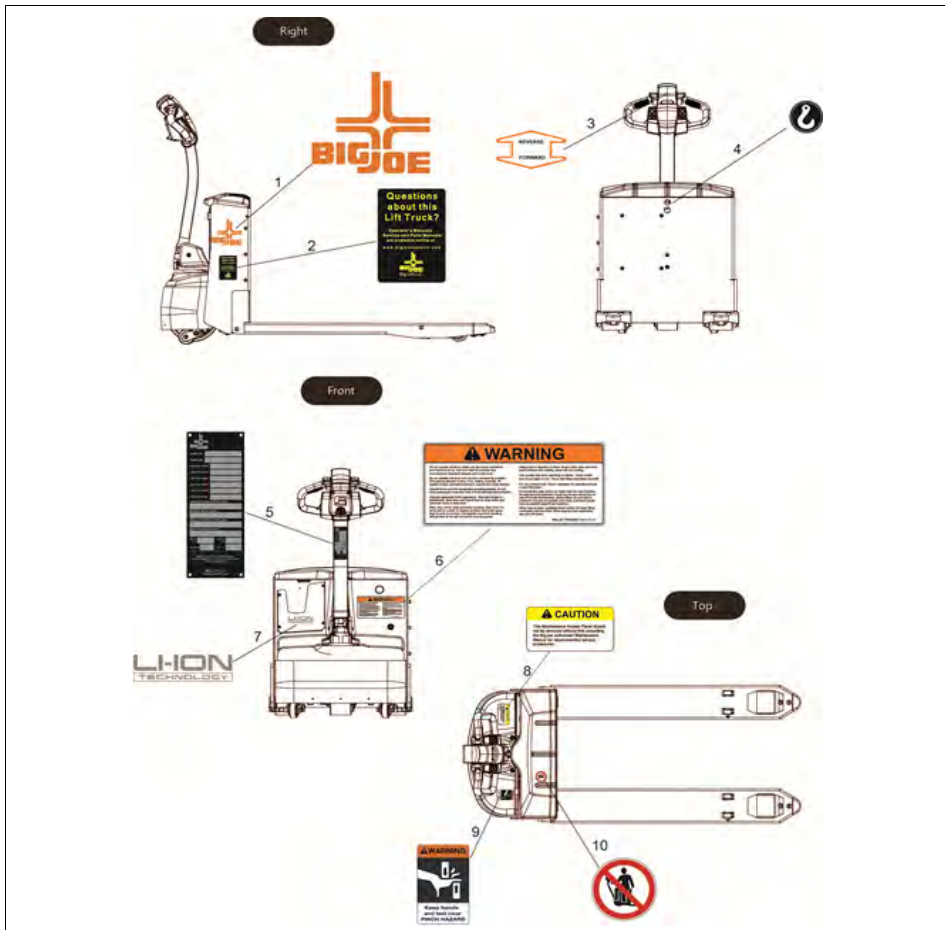

LPT44 Name Plate and Warning Decal Locations - Typical

ITEM	COMPONENT	ITEM	COMPONENT
1	Big Joe Decal	6	Warning Decal
2	Support Decal	7	Li-Ion Decal
3	Forward and Reverse Decal	8	Caution Decal
4	Lift Point Decal	9	Pinch Hazard Decal
5	Name Plate	10	“Do not stand” Decal

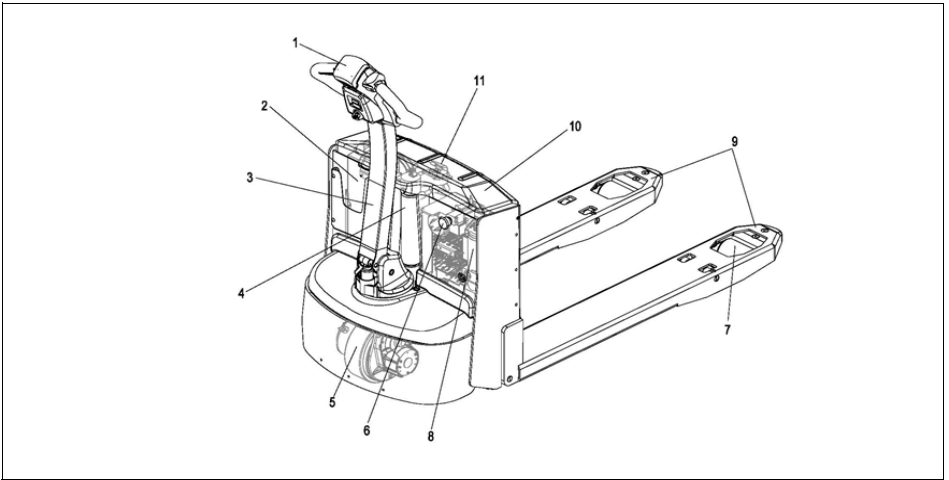

Truck Overview

ITEM	COMPONENT	ITEM	COMPONENT
1	Control Handle	7	Load Wheels
2	Battery	8	Pump and Motor Assembly
3	Steering Arm	9	Forks
4	Lift Cylinder	10	Top Cover
5	Drive Wheel	11	Charger Cable
6	Emergency Stop Switch		



WARNING:

This truck is equipped with a battery. Read and heed the following warning plus any other warnings located near or on the battery. An example is shown here:

LOAD CAPACITY

Do not overload truck. Check name plate for load weight capacity and load center information.

The load capacity depends on the load center. The load maximum capacity listed on the capacity plate assumes a uniform load whose center is at 1/2 the length of the fork and centered between the forks. The maximum load capacity is reduced when the load center exceeds 1/2 the length of the forks or is not centered between the forks. The fork length and wheel-base must be adequate for the skid or bin to be handled.

Note that a truck undergoing speed changes is less stable than a standing truck. If you are not sure that the truck can lift a certain load, consult your supervisor or the designated authority.

BIG JOE

MODEL NO. _____

SERIAL NO. _____

MAX CAP LB/KG _____

LOAD CTR IN/MM _____

LIFT HGT IN/MM _____

ALT CAP LB/KG _____

LOAD CTR IN/MM _____

LIFT HGT IN/MM _____

TRUCK WT LESS BATTERY LB/KG _____

BATTERY MIN WT LB/KG _____

TRUCK WT WITH BATTERY LB/KG _____

BATTERY MAX WT LB/KG _____

TRUCK TYPE _____ BATTERY TYPE _____

CERTIFIED _____ VOLTAGE _____

COMPLIES WITH THE APPLICABLE REQUIREMENTS OF ANSI/ITSDF B56.1 STANDARDS

BIG LIFT LLC
www.blglift.com

Name Plate

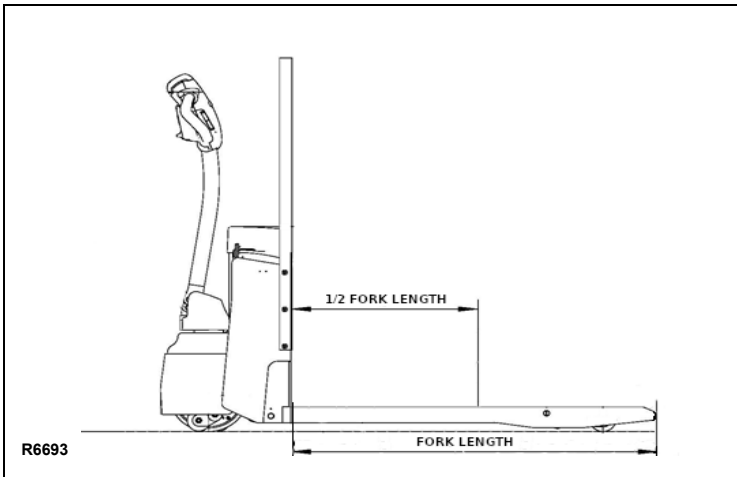

Load Center

BEFORE OPERATION

The table on [page 11](#) covers important inspection points on trucks which should be checked prior to operation. Depending on use, some trucks may require additional checks.

The illustration below shows a sample format for an Operator Checklist, which can be modified as necessary to fit your operation.



WARNING:

Periodic maintenance of this truck by a QUALIFIED SERVICE TECHNICIAN is required.



WARNING:

A QUALIFIED SERVICE TECHNICIAN should check the truck

monthly for proper lubrication, proper fluid levels, brake maintenance, motor maintenance and other areas specified in the parts and service manual maintenance section.



WARNING:

If the truck is found to be unsafe and in need of repair, or contributes to an unsafe condition, report it immediately to the designated authority. Do not operate it until it has been restored to a safe operating condition. Do not make any unauthorized repairs or adjustments. All service must be performed by a qualified service technician.

Sample of Operator Check List



Electric Truck Daily Operator Check-Off List

Date _____ Operator _____

Truck No. _____ Model No. _____

Dept. _____ Shift _____

Hour Meter
Reading —Drive _____ Hoist _____

Check	O.K. (✓)	Need Maintenance
Tires		
Load Wheels		
Horn		
Lift—Lower Control		
Attachment Operation		
Forward & Reverse Controls		
Steering		
Electrical Brakes		
Hydraulic Leaks, Cylinders, Valves, Hoses, Etc.		

Operator Checks

ITEM	PROCEDURE
Transmission and hydraulic systems	Check for signs of fluid leakage and/or abnormal noise.
Forks and Frame	Check for cracks and damage.
Guards and load backrest	Check that safety guards are properly secured and not damaged.
Safety signs	Check that warning labels, nameplate, etc., are in good condition and legible.
Horn	Check that horn sounds when operated.
Steering	Check for binding or looseness in steering arm when steering.
Tiller switch/Parking brake	Check that steering arm raises to upright position when released and brake applies.
Brakes	Check that brakes actuate when steering arm is raised to upright position, and when lowered to horizontal position.
Travel controls	Check that speed controls on control handle operate in all speed ranges in forward and reverse and that belly button switch functions.
Wheels	Check drive wheel for flat spots, cracks or damage. Move truck to check load wheels for freedom of rotation.
Hydraulic controls	Check operation of lift and lower to their maximum positions. Check the oil levels.
Electrical	Check that there is no damage to the cables on the truck and that the horn and lift buttons work.
Battery disconnect	Check that battery can be disconnected and reconnected. Check for connector damage.

INSTRUMENTS AND CONTROLS

The steering arm and control handle provide controls for steering, forward and reverse speed control, braking, raising and lowering the forks, and horn. Control handles on all models have a “belly-button” reversing switch which reverses the direction of the truck upon contact with the operator.

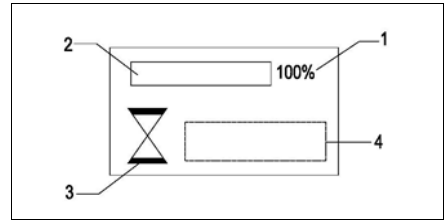

Display Unit

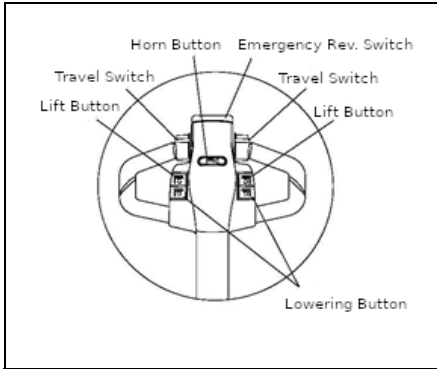

Control Handle - Top

On the LPT44 pushing the red disconnect plunger removes all power from the truck circuits in the event of an emergency.



Control Handle - Back

Display Unit

- The LED display (1) shows the residual battery capacity, when it's lower than 20% it must be charged.
- When the display (2) shows “NO BMS” the communication with the battery is disconnected and when it shows “BMS EER” the battery temperature or voltage is unbalanced.
- When display (3) is solid On the interlock switch is open. when flashing the interlock switch is closed and the running time will start.
- The display (4) will normally show the total running time whoever if there is a fault code on the truck it will be displayed here.

The display unit has a range between 0 to 99999 hours and it will log hours when traveling or lifting.

The battery discharge indicator has a memory function. It will display the state of charge (SOC) stored in memory, until a full charge cycle has been completed, and the battery SOC reset threshold is exceeded

Low Voltage Protection

When the battery power is low the Low Voltage Protection will prevent must charge battery.

the forks from being raised and you

OPERATION

Driving Instructions

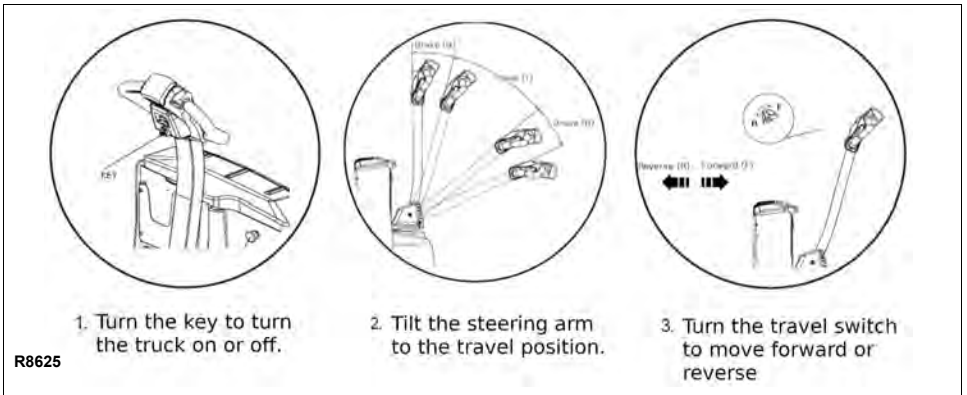

Forward and Reverse Travel and Speed Control

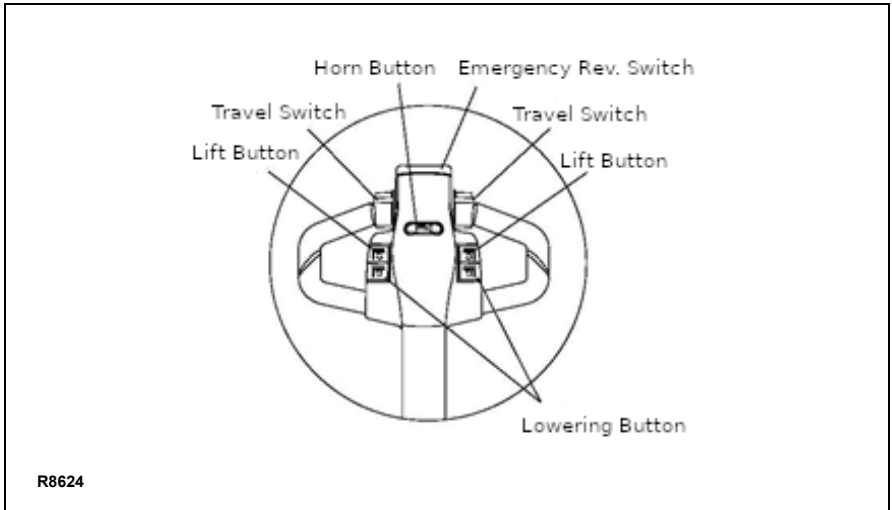

Control Handle

Control Handle

All directional and speed controls are located on the control handle.

Forward and reverse are controlled by rotating the speed control lever as shown. The lever is spring loaded to return to neutral when released. Further rotation in either direction will

progress the truck from slow to maximum travel speed.

To change directions or to stop the truck, rotate the speed control lever in the opposite direction. The truck will come to a stop and then, unless the controls are returned to the center neutral position, accelerate in the opposite direction.

Steering

Moving the control handle (which connects to the steering arm) right or left will turn the truck right or left. When maneuvering around corners, make square turns and be sure there is adequate clearance.

Stopping

Stop the truck as gradually as possible. Unnecessary rapid stopping could be hazardous. Load could become unstable.

To stop the truck's movement (forward or reverse), raise the control handle to the up position or push the control handle all the way down. In both positions, the brake will apply. To release the brake, just move the control handle to the operating position.

NOTE: The steering arm gas spring automatically raises the steering arm to the upright position when the steering arm is released.

CAUTION: If the control handle does not raise immediately to the vertical position when released, the truck should be placed "OUT OF SERVICE" until it can be inspected by a qualified service technician.

Parking

When parking the truck, do not obstruct traffic lanes or aisles.

1. Park the truck in its designated parking area.
2. Raise the steering arm until vertical to apply parking brake.
3. Fully lower forks.

4. Remove the key from the keyhole.
5. On the LPT44 push the red disconnect plunger to remove all power from the truck circuits.

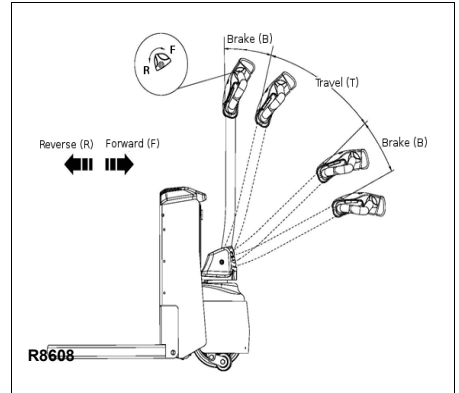

Steering Arm Braking Positions

Load Handling

Handle only loads arranged for stability and always use caution. Raise and lower the load smoothly to prevent the load from falling.



WARNING:

Always be sure the load and load center are within the capacity of the truck. If in doubt check the nameplate.

1. Approach the load slowly.
2. Move the truck slowly into position so that the forks are within pallet or skid, and the load is centered over the forks and as far back as possible.
3. Push the button to raise the forks and lift the load.

4. Lead the truck by the control handle with the load trailing except when in confined areas. Ramps should be traveled with operator uphill of truck when empty, or operator downhill of truck with load on forks standing off to side of truck.
5. Always look in the direction of travel. Move slowly and check clearances when approaching obstructions.
6. Do not make sudden starts and stops. Operate truck smoothly and gradually.
7. Travel slowly and squarely around corners. Remember that the trailing load wheels do not follow the turn path of the drive wheel. Instead they tend to cut the corner.
8. Line up the truck with the unloading area.
9. Stop the truck and check the load alignment with surrounding objects.
10. Be careful not to damage or move adjacent loads and objects.
11. Lower the forks by pulling the lowering lever until the load is resting on its own.
12. Move the truck back until the forks are clear of the pallet.

Moving a Disabled Truck

Do not attempt to move a disabled truck; notify your supervisor or proper authority.

Battery Charging



WARNING: Before removing the battery make sure that the truck is completely powered down.



WARNING: Before installing the battery make sure that the truck key is not on.

Using internal charger

Proceed as follows:

1. Park truck at charging station with forks lowered and turn the key switch off.
2. Check the condition of the AC cord. If there are any cuts in the cable, any exposed wires, loose plugs or connectors, DO NOT attempt to charge the batteries. Contact appropriate personnel for repairs to be made.
3. Pull the charger cord (1) out of the top cover (Figure 3-1) and connect to the appropriate power supply.

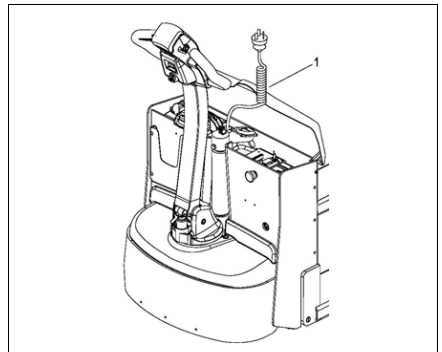

Internal Battery Charging

Using External Charger

Proceed as follows:

1. Park truck at charging station with forks lowered and turn the key switch off.
2. Unlock the battery lock and with the battery handle slowly pull the battery straight up.

3. Make sure the charger is plugged in and then insert the battery to the charger cradle.

The LEDs should light up.

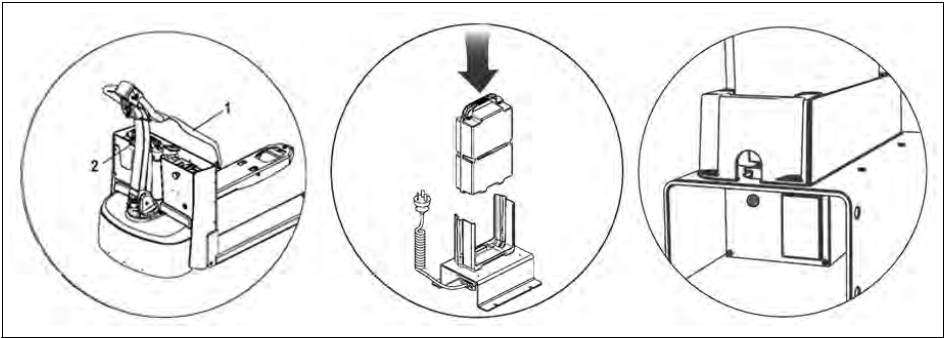

External Battery Charging

INDICATOR	COLOR	DESCRIPTION
	Solid Red	Charger Fault - (See display panel for details)
	Flashing Amber	External error condition - Caution (See display panel for details)
	Flashing Green	USB port active
	Solid Green	Safe to remove USB flash drive
	Flashing Green	Low state of charge
	Solid Green	High state of charge
	Flashing Green	High state of charge
	Solid Green	Charge completed
	Solid Blue	AC power available

Charger LED Status Indicator

NOTE: The figure above shows the view of how to plug the charger in to the charger base, make sure you plug in the battery accordingly.

NOTE: When plugging in the battery on the truck make sure that the contact pins on the battery match those on the truck.

NOTE: With a lithium battery it is possible to have some attenuation when used in a low temperature environment. The operating temperature for the lithium battery is between 14°F - 113°F.

The following operating instructions appear on the truck warning decal, which is located near the steering arm.

Do not operate this truck unless you have been trained and authorized to do so, and have read and understand all warnings and instructions contained in this operator's manual and on this truck.



R8627

Do not operate this truck until you have checked its condition. Give special attention to wheels, horn, battery, controller, lift systems, brakes, steering mechanism, guards and safety devices. If you have any questions, notify your supervisor or proper authority.



R8628

Walkie Pallet Trucks: Operate truck only from walking position.



R8629

Wear foot protection and keep feet clear of truck.



R8630

Do not carry passengers.



R8631

Observe applicable traffic regulations. Yield right-of-way to pedestrians. Slow down and sound horn at cross aisles and wherever vision is obstructed.

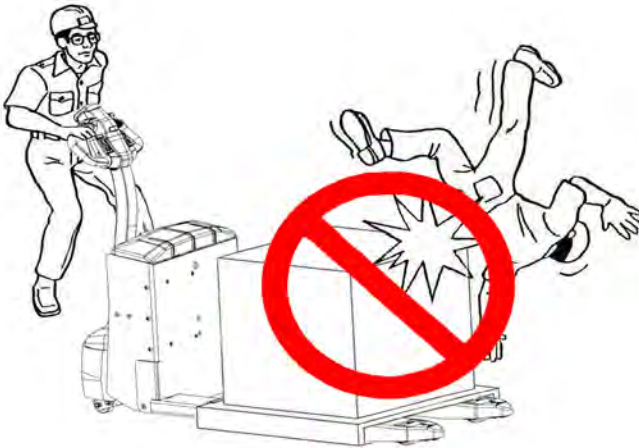

R8643



R8635

Start, stop, travel, steer and brake smoothly. Slow down for turns and on uneven or slippery surfaces that could cause truck to slide or overturn. Use special care when traveling without load as the risk of overturn may be greater.

Always look in direction of travel. Keep a clear view, and when load interferes with visibility, travel with load or lifting mechanism trailing (except when climbing ramps).

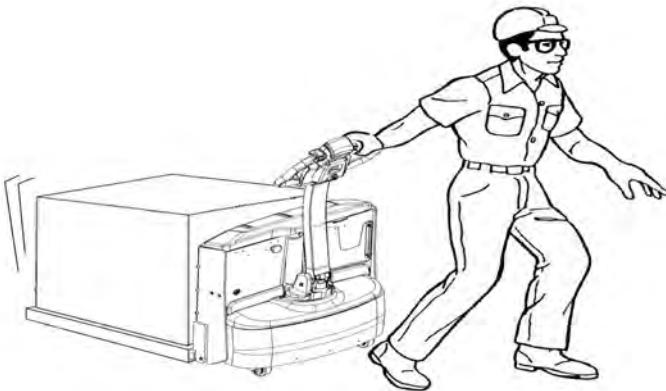

R8636

Use special care when operating on ramps; travel slowly, and do not angle or turn. Travel with lifting mechanism downhill.



R8637

Do not handle loads which are higher than load backrest or load backrest extension unless load is secured so that no part of it could fall backward.



R8638

When leaving truck neutralize travel control. Fully lower lifting mechanism and set brake. When leaving truck unattended also shut off power.

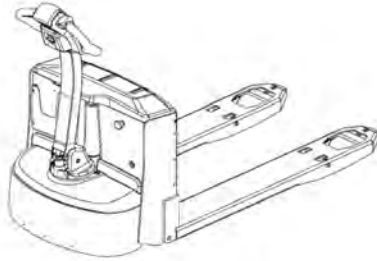

R8632

When leaving the truck for an extended period of time remove the battery.

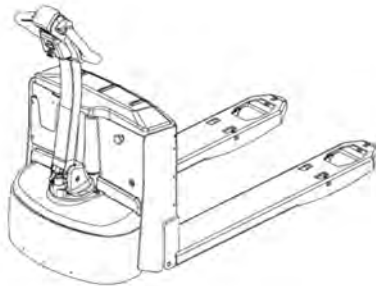

R8633

NOTICE - OBTAINING A PARTS AND SERVICE MANUAL

A complete parts and service manual covering this truck is available from Big Lift LLC. To order, obtain the serial number of your truck and download from www.bigjoesupport.com or you can contact your Big Joe Authorized Dealer.



BIGJOE[®]