



MATERIAL HANDLING PRODUCTS



One Million Square Feet
of Production Facilities



DREXEL®

SL40AC/2

SL50AC/2

ANYTHING ELSE is a **WASTE** of **SPACE!**

TOTAL
WAREHOUSE

STANDARD FEATURES

- 4,000 lb. (1,814kg) and 5,000 lb. (2,268kg) Capacity at 24" (610mm) Load Center
- Lift Heights to 374" (9.5M)
- 56" (1.4M) Stacking Aisle
- High Visibility 3-Stage or 4-Stage Mast
- 48 Volt CAN-Bus Electrical System
- AC Traction and Hydraulic Controllers with Lift Interrupt
- Hydraulic Power Steering by Main Hydraulic Pump (No Separate Power Steering Pump or Motor)
- Full Diagnostic Interactive Display with Battery Discharge Indicator and Hour Meter
- Four-Wheel Design, Dual Front Wheel Planetary Drives and Heavy Duty Articulating Rear Steer Axle
- Right Side 16½" (419mm) Deep Long Load Deck
- Large Diameter Poly Drive and Poly Steer Tires
- 22" (559mm) of Mast Shift, Includes 3" (76mm) of Reach and 90° Right Side Mast Rotation
- Comfortable Seated Operation with Single Joystick Hydraulic and Directional Control on Armrest
- Mast Tilt of 3° Forward and 4° Back
- Adjustable Cloth Suspension Swivel Seat with Adjustable Armrests
- Adjustable Steering Column, Key Switch, Rear View Mirror, Horn, Seat Belt
- Safety Seat Switch and Retractable Seat Belts
- Hydraulic Front-Wheel Disc Brakes
- Mast Tilt Indicator
- 4-Post Adjustable Overhead Guard, Meets ANSI B56.1
- 40" (1,000mm) Long End Tapered Forks, 37" (940mm) Wide Carriage and 36" (914mm) High Load Backrest
- Provisions for RF Terminals
- Accepts Class II Attachments
- Easily Accessible Components for Low Cost Maintenance
- UL 583 Type E, UL Listed



Scan the QR Code
to Learn More!



OPTIONAL FEATURES

- LandGuide - Wire Guidance System
- Non-Standard Fork Lengths
- LED Headlights, Flashing Light and Rear Safety Lights
- Back-Up Alarm
- Integral Fork Positioner
- Auxiliary Hydraulics
- Non-Marking Tires
- UL 583 Type EE Electrical Rating, UL Listed
- Vinyl Seat
- Fire Extinguisher
- Lazer Fork Height Indicator
- Camera with Operator Compartment Monitor
- 42" (1,067mm) Wide Fork Carriage
- Battery Compartment Roll Out Tray
- Long Load Handling Deck Mount
- Capable of Freezer Operation to -22°F (-30°C)

4-Wheel VNA Swing Mast™ Electric Multi-Purpose Pallet Load Handler and Long Load Side Loader

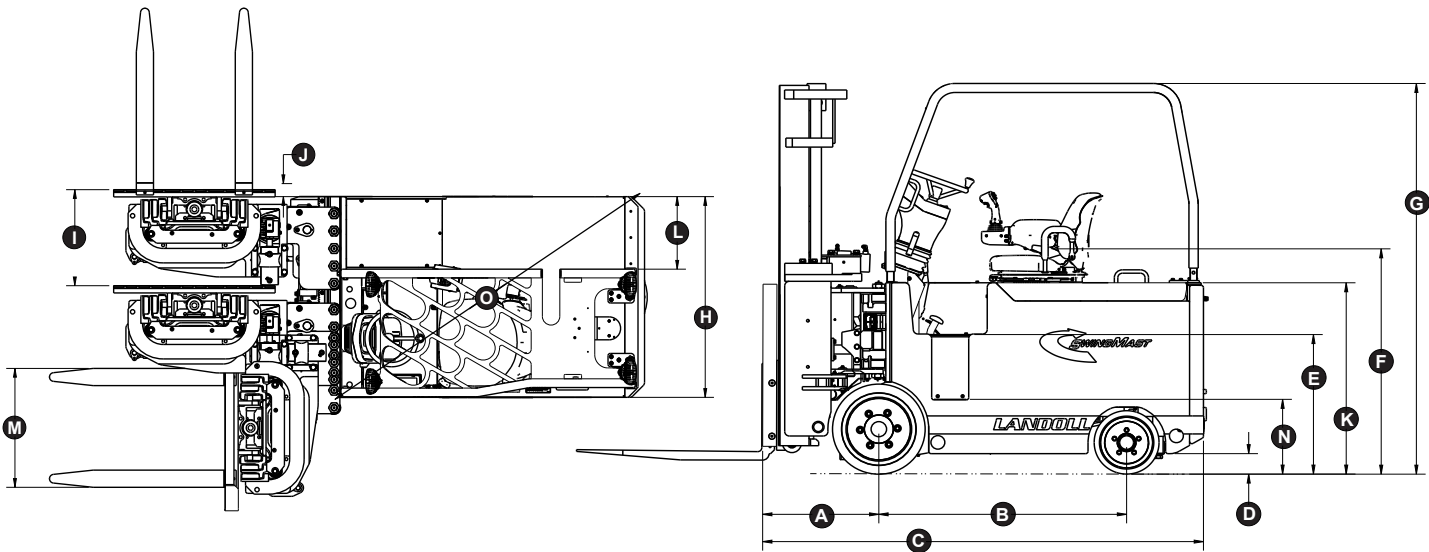

TECHNICAL DATA

MODEL				SL40	SL50
Capacity			lbs/kg	4,000 / 1,814	5,000 / 2,268
Load Center			in/mm	24 / 600	24 / 600
Weight		with Battery	lbs/kg	13,800 / 6,272	15,100 / 6,864
Travel Speed		Loaded	mph/kph	6.5 / 10.5	6.5 / 10.5
		Unloaded	mph/kph	7 / 11.3	7 / 11.3
Lift Speed		Loaded	fpm/mpm	90 / 27.4	90 / 27.4
		Unloaded	fpm/mpm	110 / 33.4	110 / 33.4
Lowering Speed		Loaded	fpm/mpm	100 / 30.5	100 / 30.5
		Unloaded	fpm/mpm	90 / 27.4	90 / 27.4
Mast Tilt		to 293" (7.44M)	fwd/back	3 / 4	3 / 4
Mast Underclearance			in/mm	5 / 127	5 / 127
Lost Load Center	A	with Triple Mast	in/mm	25 / 635	25 / 635
Wheelbase	B		in/mm	53.5 / 1,359	53.5 / 1,359
Overall Length	C	with Triple Mast	in/mm	95.25 / 2,419	96.25 / 2,445
Rear Underclearance	D		in/mm	4.5 / 114	4.5 / 114
Cab Floor Height	E		in/mm	31 / 787	31 / 787
Seat Height	F		in/mm	50 / 1,270	50 / 1,270
Overhead Guard Height	G		in/mm	87 / 2,210	87 / 2,210
Chassis Width	H		in/mm	46 / 1,168	46 / 1,168
Mast Shift	I		in/mm	22 / 559	22 / 559
Side Reach	J		in/mm	3 / 76	3 / 76
Side Deck Height	K		in/mm	42.5 / 1,080	42.5 / 1,080
Side Deck Width	L		in/mm	16.5 / 419	16.5 / 419
Fork Carriage Width	M		in/mm	37 / 940	37 / 940
Step Height	N		in/mm	16.5 / 419	16.5 / 419
Turning Radius	O			83 / 2,108	83 / 2,108
Fork Length			in/mm	40 / 1,016	40 / 1,016
Gradeability		Loaded	%	15	15
Hydraulic Motor Rating		Continuous Duty Rating	type/kWh	AC / 16.8	AC / 16.8
Traction Motor Rating		Continuous Duty Rating	type/kWh x 2	AC / 5.6 = 11.2	AC / 5.6 = 11.2
Drive Tire Type				Smooth Poly	Smooth Poly
Drive Tire Size		Diameter x Width	in/mm	20x9 / 508x229	20x9 / 508x229
Steer Tires		Poly - Diameter x Width	in/mm	14x5 / 356x128	14x5 / 356x128

AISLE DIMENSIONS

LOAD DEPTH X WIDTH	MINIMUM CLEAR AISLE
40" x 48" (1,000 x 1,200mm)	56" (1,422mm)
48" x 40" (1,200 x 1,000mm)	60" (1,524mm)
Minimum Clear Transfer Aisle with Load	138" (3,505mm)

RECOMMENDED BATTERIES

BATTERY DESIGNATION: 24-100-21, 48 VOLT, 1,000 AHC
Battery Weight Min. 3,250 lbs. (1,477kg) - Max. 3,900 lbs. (1,773kg)
Leads are at Position B, 18" (45.7cm) Long, with SB 350 Amp Blue Connector
Nominal Size: 33" x 38.5625" x 25.625" (84 x 98 x 65cm)
Compartment Size: 33.5" x 38.625" x 25.75" (85 x 98 x 65cm)

QUALITY IS OUR FIRST PRIORITY



Exceptional Customer Support, Parts and Service

Landoll is committed to total customer satisfaction by providing products and services of the highest quality. Aftermarket parts and service is available world-wide through our factory trained dealer network and Landoll's service support department. Our 75,000 square foot Parts Distribution Center ensures quick and accurate delivery of parts to keep your equipment up and running. Experience for yourself the reason that Landoll Material Handling Products are #1 in customer retention.

Proven Solutions for Storage & Specialty Handling Applications

Family owned and operated since 1963, we make quality our first priority. Our goal is to provide the best solution for your material handling needs. Bendi articulating, Drexel SwingMast® Narrow Aisle and Very Narrow Aisle forklifts provide that solution. Through increased utilization of space, improved productivity, greater flexibility and maximized efficiency. We stay on the edge of modern and innovative technology. We know that for our customers "Quality is Always a Bargain".

FORKLIFT AISLE COMPARISON

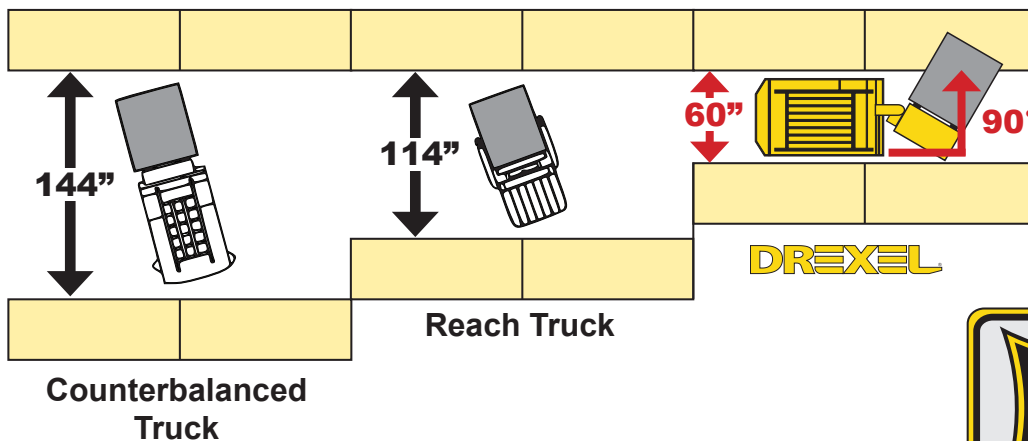

Drexel VNA Forklifts save on warehouse space by **33%** compared to a reach truck and by **51%** compared to a counterbalanced truck.



MATERIAL HANDLING PRODUCTS

landoll.com/mhp

1900 North Street Marysville, KS 66508 · 800-428-5655 · forkliftsales@landoll.com

