



## Li-ION Pallet Truck

# MT15B

Capacity 3,300 lb. | Series 8932

- Small size and reduced weight for improved maneuverability
- Lift 3,300 lb. at 24 in. load center to the max height of 7.5 in. with ease
- Equipped with a 20Ah Li-ion battery, the onboard charger enables quick charging, maximizing operational flexibility.
- All operator controls available without lifting one's hand from the ergonomic grips

# STANDARD & OPTIONAL EQUIPMENT

		MT15B
Fork dimension	27 in W x 45 in L (685 mm x 1150 mm)	●
Drive cover off the ground	2.1 in (55 mm)	●
Load wheel type	Single <b>Polyurethane</b>	●
Polyurethane Load & Drive wheels		●
Battery capacity	24V/20AH - Qty.1 With Onboard Charger	●
	24V/20AH - Qty.2 With Optional off board Charger	○
Charger	24V-10A external charger	○
Battery indicator		●
Square-tube tiller head		●
Castor wheels		○

● Standard equipment    ○ Optional equipment

## MT15B TECHNICAL DATA

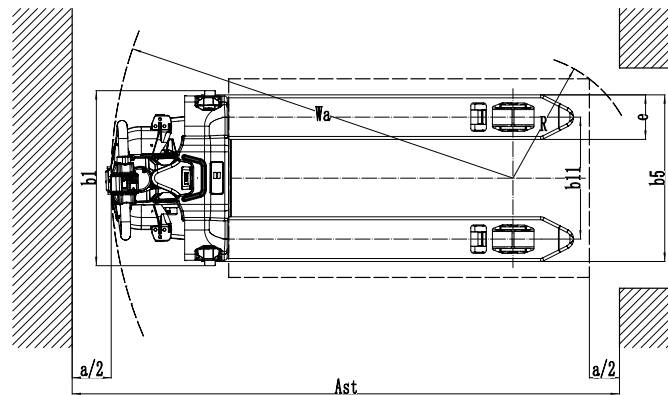
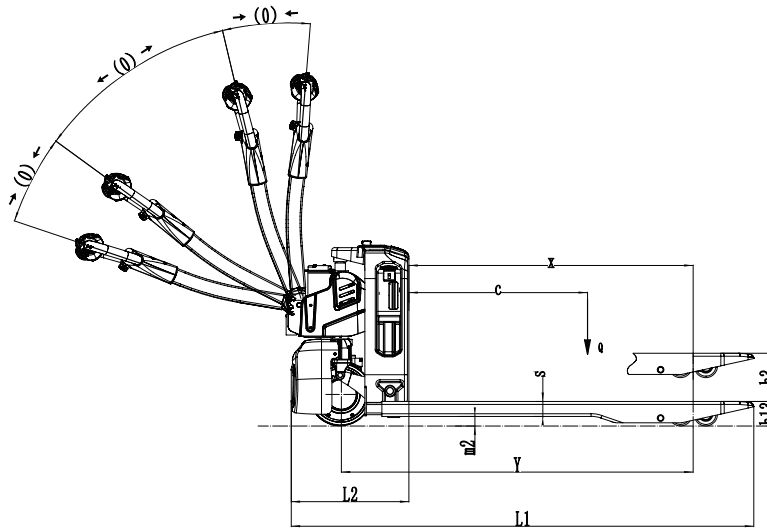

# MT15B TECHNICAL DATA

Characteristics	1.1	Manufacturer				LINDE	
	1.2	Model designation				MT15B	
	1.2a	Series				8932	
	1.3	Drive system				Li-ION battery	
	1.5	Rated capacity/rated load	Q	lb	kg	3,300	1497
	1.6	Load center distance	c	in	mm	24	600
	1.8	Load distance, center of drive axle to fork	x	in	mm	37.4	950
	1.9	Wheelbase	y	in	mm	46.4	1180
	Weights	2.1	Service weight		lb	kg	264.5
2.3		Axle loading, unloaded front/rear		lb	kg	198/66	90/30
Wheels/Tires	3.1	Tire type				Polyurethane	
	3.2	Tire size, front		in	mm	8.26x2.7	210/70
	3.3	Tire size, rear		in	mm	3.14x3.36	80/60
	3.4	Additional wheels (castor wheels)		in	mm	2.91x1.18	74/30
	3.5	Wheels, number front/rear (× = driven wheels)				1x2	
	3.6	Tread width, front	b10	in	mm	---	
	3.7	Tread width, rear	b11	in	mm	16.14 (13.89)	410 (535)
Dimensions	4.4	Lift	h3	in	mm	4.13	105
	4.9	Height of tiller handle in drive position min./max.	h10	in	mm	29.5/46.8	750/1190
	4.15	Lowered height	h13	in	mm	3.2	82
	4.19	Overall length	l1	in	mm	61	1550
	4.20	Length to face of forks	l2	in	mm	15.7	400
	4.21	Overall width	b1/b2	in	mm	23.2 (27.3)	590 (695)
	4.22	Fork dimensions	s / e / l	in	mm	1.9/5.9/45.2	50X150X1150
	4.25	Distance between fork-arms	b5	in	mm	22 (26.9)	560 (685)
	4.34.1	Aisle width for pallets 1000×1200 crossways	Ast	in	mm	85	2160
	4.34.2	Aisle width for pallets 800×1200 lengthways	Ast	in	mm	79.72	2025
4.35	Turning radius	Wa	in	mm	53.54	1360	
Performance	5.1	Travel speed, loaded/unloaded		mph	km/h	2.8/2.8	4.5/4.5
	5.2	Lift speed, loaded/unloaded		fpm	m/s	3.34/ 3.93	0.017/0.02
	5.3	Lowering speed, loaded/unloaded		fpm	m/s	11.41/9.05	0.058/0.046
	5.8	Max. gradeability, loaded/unloaded			%	5/16	
	5.10	Service brake				Electromagnetic	
Drive	6.1	Drive motor rating S2 60 min			kW	0.75	
	6.2	Lift motor rating at S3 15%			kW	0.5	
	6.4	Battery voltage/nominal capacity			V / Ah	24/20	
	6.5	Battery weight (± 5%)		lb	kg	11	5
	6.6	Energy consumption according to DIN EN 16796			kWh/h	0.18 <sup>1</sup>	
	6.7	Turnover output according to VDI 2198			t/h	88	
	6.8	Turnover efficiency according to VDI 2198			t/kWh	473.12	
	8.1	Type of drive control				BLDC	
Others	10.5	Steering design				Mechanical	
	10.7	Sound pressure level LpAZ (at the driver's seat)			dB(A)	74	
	15.1	Charger output current			A	---	

# CHARACTERISTICS



## Li-ion Technology

- The MT15B comes with a standard 20Ah Li-ion battery and onboard charger, which offers high availability to multishift work thanks to fast and flexible charging and zero maintenance.
- Optimized for opportunity charging when pallet truck is not in use
- Up to 3-hour battery charge, or up to 6 hours with optional secondary Li-ion battery in place of on-board charger



## Ergonomics

- The low-mounted tiller arm offers excellent operator comfort and minimum steering effort.
- Travel, lift, and lower functions are located on the ergonomic control head.
- The control head is designed for easy operation with either hand and includes a belly button reversing switch, dual butterfly travel controls, horn, and battery discharge indicator.
- Creep speed functionality and small size give operator confidence in tight spaces

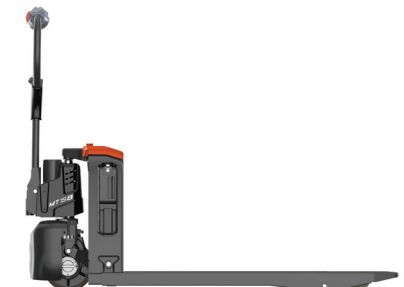

## Cost Reductions

- Maintenance-free Lithium-Ion battery improves battery life and working efficiency
- Reduce electrical costs because of better charger efficiency

For more information on Linde Material Handling equipment, please contact:



KION North America Corporation  
2450 West 5th North Street, Summerville, SC 29483  
Phone: (843) 875.8000 Truck Sales Fax: (843) 875.8471  
Email: [trucksales.na@kiongroup.com](mailto:trucksales.na@kiongroup.com)  
[www.kion-na.com](http://www.kion-na.com)

Linde Material Handling

Member of KION Group