



ELECTRIC FORKLIFT TRUCKS

E18 / E20

3,500 - 4,000 lbs. Capacity

Series 346

TOTAL
WAREHOUSE

- Lowest energy consumption combined with high residual capacity meets the need for maximum versatility in a truck that fits most applications
- Linde Load Control coordinates the dual AC-motor drive axle and electronic control levers to provide stable and precise load handling for any variety of products
- Compact maneuverability through a heavy-duty steer axle (E18/E20).
- The standard full-suspension seat with tilt-up armrest and electronic fingertip control levers encourage productive operators with fewer fatigue-related injuries throughout the workday

STANDARD & OPTIONAL EQUIPMENT

STANDARD

- 36-volt or 48-volt chassis
- Dual-pedal travel control
- Cushion tires
- Low-height, lift-out battery exchange
- Standard 80.5" overhead guard
- Three-function hydraulic valve
- Three-function electronic control levers
- Linde Load Control
- Standard tilt (6°F / 5°B)
- Full-suspension vinyl seat with tiltable armrest
- Adjustable padded armrest
- Two front work lights
- Key switch start
- SB350 battery connector
- Emergency power interrupt button
- UL classification, Type E
- Black, non-cinching seat belt
- Maintenance-free wet-disc brakes
- 100% AC traction and lift motors
- Multi-function display indicator
- Tow pin and tie-down cutouts
- Electronic forward horn
- Hydrostatic power steering system
- Adjustable steering column
- Linde Curve Assist speed-control
- Steel entry handle
- Spring-assisted battery cover
- 1000-hour maintenance intervals
- 3-year / 6000-hour (standard warranty)

OPTIONAL

- Single-pedal travel control
- Pneumatic-shaped solid tires (SE)
- Non-marking tires
- Side battery removal with slides/rollers
- Simplex, duplex, triplex, and quad masts
- 38.6" Class II fork carriage
- Integrated / hang-on sideshifter
- Low-profile and drive-in rack overhead guard
- Four-function hydraulic valve
- Four-function electronic control levers
- Bottler's tilt (10°F / 4°B)
- Auxiliary function hydraulic hose reeving
- Quick-disconnect hydraulic fittings
- High comfort textile seat with tiltable armrest
- Tilt angle memory
- Load backrest extension 48"
- LED work lights
- Linde BlueSpot™
- LED rear combination light bars
- Flashing amber strobe light
- Back-up alarm
- Rear handle with horn button
- Fire extinguisher (2.5 lb dry chemical)
- Panoramic rear-view mirror
- Flat rear-view mirror
- High-visibility orange seat belt
- Keyless start switch
- Operator fan
- Cold-storage protection
- UL classification, Type EE

Capacity*

E18

1.5" x 4" x 42" Std. Taper Class II Forks**
Cushion Tires 18 x 7 x 12.13 Drive Tires**
Class II Sideshifter • Back Tilt Angle = 5°

Mast Capacity Table

h1	h3	h2		Std. Carriage	Integral SS Carriage	Hang-on SS Carriage*
80.0	122.0	00.0	Simplex	3500	3500	3250
84.0	129.5	00.0	Simplex	3500	3500	3250
91.5	145.5	00.0	Simplex	3500	3500	3250
77.5	168.0	53.0	Triplex	3500	3500	3250
79.5	174.0	55.0	Triplex	3500	3500	3250
84.0	188.0	59.5	Triplex	3500	3500	3250

E20

1.5" x 4" x 42" Std. Taper Class II Forks**
Cushion Tires 18 x 7 x 12.13 Drive Tires**
Class II Sideshifter • Back Tilt Angle = 5°

Mast Capacity Table

h1	h3	h2		Std. Carriage	Integral SS Carriage	Hang-on SS Carriage*
80.0	122.0	00.0	Simplex	4000	4000	3750
84.0	129.5	00.0	Simplex	4000	4000	3750
91.5	145.5	00.0	Simplex	4000	4000	3750
77.5	168.0	53.0	Triplex	4000	4000	3750
79.5	174.0	55.0	Triplex	4000	4000	3750
84.0	188.0	59.5	Triplex	3600	3600	3350

*For quick reference only, contact factory for detailed ratings. **Capacity ratings can be affected by changing forks, load center, and/or drive tires.

Technical Data

E18

August 2010

Characteristics	1.1	Manufacturer		Linde	
	1.2	Model designation		E18	
	1.2.1	Chassis configuration		3-Wheel	
	1.3	Power unit: battery, diesel, LP gas		36-Volt Battery	48-Volt Battery
	1.4	Operation: manual, pedestrian, rider standing, rider seated, order picker		Rider seated	
	1.5	Load capacity	<i>Q lb</i>	3500	
	1.6	Load center	<i>c in</i>	24	24
	1.8	Load distance (front overhang)	<i>x in</i>	15.4	15.4
	1.9	Wheelbase	<i>y in</i>	55.9	55.9
Weight	2.1	Service weight with min. battery	<i>lb</i>	8355	8355
	2.2	Axle loading with load, front/rear	<i>lb</i>	10495 / 1361	10495 / 1361
	2.3	Axle loading without load, front/rear	<i>lb</i>	4411 / 3945	4411 / 3945
Wheels & Tires	3.1	Tire type - front/rear: cushion, cushion super elastic, pneumatic)		Cushion ¹⁾	Cushion ¹⁾
	3.2	Tire size: front	<i>in</i>	18 x 7 x 12.13	18 x 7 x 12.13
	3.3	Tire size: rear	<i>in</i>	15 x 5 x 11.25	15 x 5 x 11.25
	3.5	Wheels: number front/rear (x = driven)		2x / 2	2x / 2
	3.6	Track width, front	<i>b10 in</i>	35.0	35.0
	3.7	Track width, rear	<i>b11 in</i>	6.8	6.8
	Dimensions	4.1	Mast/fork carriage tilt: forward/back	<i>degrees</i>	6° / 5°
4.2		Height of mast lowered	<i>h1 in</i>	See mast table	See mast table
4.3		Free lift	<i>h2 in</i>	See mast table	See mast table
4.4		Lift	<i>h3 in</i>	See mast table	See mast table
4.5		Height of mast extended	<i>h4 in</i>	See mast table	See mast table
4.7		Height of overhead guard/cab	<i>h6 in</i>	80.5 ²⁾	80.5 ²⁾
4.8		Height of seat	<i>h7 in</i>	38.9	38.9
4.12		Height of tow coupling	<i>h10 in</i>	23.0	23.0
4.19		Overall length with 42" forks	<i>l1 in</i>	121.3	121.3
4.20		Length to fork face	<i>l2 in</i>	79.4	79.4
4.21		Overall width	<i>b1/b2 in</i>	42.0 ⁴⁾	42.0 ⁴⁾
4.22		Fork dimensions	<i>s/e/l in</i>	1.5 x 4.0 x 42.0	1.5 x 4.0 x 42.0
4.23		Fork carriage: class		Class II	Class II
4.24		Width of fork carriage	<i>b3 in</i>	38.6	38.6
4.31		Ground clearance under mast, with load	<i>m1 in</i>	2.9	2.9
4.32		Ground clearance, center of wheelbase	<i>m2 in</i>	3.3	3.3
4.33	Aisle width (must add load length and clearance)	<i>Ast in</i>	80 ³⁾	80 ³⁾	
4.35	Turning radius	<i>Wa in</i>	63.9	63.9	
Performance	5.1	Travel speed, with/without load	<i>mph</i>	8.7 / 8.7	10 / 10
	5.2	Lifting speed, with/without load	<i>fpm</i>	59 / 89	60 / 102
	5.3	Lowering speed, with/without load	<i>fpm</i>	96 / 78	96 / 78
	5.6	Maximum tractive force, with/without load (5 min. rating)	<i>lbs</i>	2450 / 2450	2200 / 2200
	5.7	Climbing ability, with/without load	<i>%</i>	16 / 23	16 / 23
	5.10	Service brake		Wet disc	Wet disc
Drive	6.1	Drive motor (60 min. rating)	<i>hp</i>	2x 5.4	2x 6.1
	6.2	Lift motor (15% rating)	<i>hp</i>	10.0	13.4
	6.3	Battery voltage	<i>V</i>	36	48
	6.4	Battery compartment dimension (l x w x h; maximum)	<i>in</i>	25.0 x 38.9 x 25.9 ⁵⁾	25.0 x 38.9 x 25.9 ⁵⁾
	6.5	Battery weight (US battery, minimum / maximum)	<i>lb</i>	2155 / 2730	2155 / 2730
Other	8.2	Working pressure for attachments	<i>psi</i>	2465	2465
	8.3	Oil flow for attachments	<i>gpm</i>	8.5	8.5

- 1) SE tire available
- 2) Lower OHG available
- 3) Add length of load plus operating clearance
- 4) 46" wide with 200/50-10 SE tires
- 5) Optional battery removal system will reduce compartment height: 23.34 w/battery rollers — 25.40 w/battery slides

Technical Data

E20

August 2010

Characteristics	1.1	Manufacturer		Linde
	1.2	Model designation		E20
	1.2.1	Chassis configuration		3-Wheel
	1.3	Power unit: battery, diesel, LP gas		36-Volt Battery 48-Volt Battery
	1.4	Operation: manual, pedestrian, rider standing, rider seated, order picker		Rider seated
	1.5	Load capacity	<i>Q lb</i>	4000
	1.6	Load center	<i>c in</i>	24 24
	1.8	Load distance (front overhang)	<i>x in</i>	15.4 15.4
	1.9	Wheelbase	<i>y in</i>	55.9 55.9
Weight	2.1	Service weight with min. battery	<i>lb</i>	8796 8796
	2.2	Axle loading with load, front/rear	<i>lb</i>	11366 / 1430 11366 / 1430
	2.3	Axle loading without load, front/rear	<i>lb</i>	4412 / 4384 4412 / 4384
Wheels & Tires	3.1	Tire type - front/rear: cushion, cushion super elastic, pneumatic)		Cushion ¹⁾ Cushion ¹⁾
	3.2	Tire size: front	<i>in</i>	18 x 7 x 12.13 18 x 7 x 12.13
	3.3	Tire size: rear	<i>in</i>	15 x 5 x 11.25 [`] 15 x 5 x 11.25
	3.5	Wheels: number front/rear (x = driven)		2x / 2 2x / 2
	3.6	Track width, front	<i>b10 in</i>	35.0 35.0
	3.7	Track width, rear	<i>b11 in</i>	6.8 6.8
	Dimensions	4.1	Mast/fork carriage tilt: forward/back	<i>degrees</i>
4.2		Height of mast lowered	<i>h1 in</i>	See mast table See mast table
4.3		Free lift	<i>h2 in</i>	See mast table See mast table
4.4		Lift	<i>h3 in</i>	See mast table See mast table
4.5		Height of mast extended	<i>h4 in</i>	See mast table See mast table
4.7		Height of overhead guard/cab	<i>h6 in</i>	80.5 ²⁾ 80.5 ²⁾
4.8		Height of seat	<i>h7 in</i>	38.9 38.9
4.12		Height of tow coupling	<i>h10 in</i>	23.0 23.0
4.19		Overall length with 42" forks	<i>l1 in</i>	121.3 121.3
4.20		Length to fork face	<i>l2 in</i>	79.4 79.4
4.21		Overall width	<i>b1/b2 in</i>	42.0 ⁴⁾ 42.0 ⁴⁾
4.22		Fork dimensions	<i>s/e/l in</i>	1.5 x 4.0 x 42.0 1.5 x 4.0 x 42.0
4.23		Fork carriage: class		Class II Class II
4.24		Width of fork carriage	<i>b3 in</i>	38.6 38.6
Performance		5.1	Travel speed, with/without load	<i>mph</i>
	5.2	Lifting speed, with/without load	<i>fpm</i>	59 / 89 60 / 102
	5.3	Lowering speed, with/without load	<i>fpm</i>	96 / 78 96 / 78
	5.6	Maximum tractive force, with/without load (5 min. rating)	<i>lbs</i>	2450 / 2450 2200 / 2200
	5.7	Climbing ability, with/without load	<i>%</i>	14 / 22 14 / 22
	5.10	Service brake		Wet disc Wet disc
	Drive	6.1	Drive motor (60 min. rating)	<i>hp</i>
6.2		Lift motor (15% rating)	<i>hp</i>	10.0 13.4
6.3		Battery voltage	<i>V</i>	36 48
6.4		Battery compartment dimension (l x w x h; maximum)	<i>in</i>	25.0 x 38.9 x 25.9 ⁵⁾ 25.0 x 38.9 x 25.9 ⁵⁾
6.5		Battery weight (US battery, minimum / maximum)	<i>lb</i>	2155 / 2730 2155 / 2730
Other	8.2	Working pressure for attachments	<i>psi</i>	2465 2465
	8.3	Oil flow for attachments	<i>gpm</i>	8.5 8.5

1) SE tire available

2) Lower OHG available

3) Add length of load plus operating clearance

4) 46" wide with 200/50-10 SE tires

5) Optional battery removal system will reduce compartment height: 23.34 w/battery rollers — 25.40 w/battery slides

Technical Data

E20C/P

August 2010

Characteristics	1.1	Manufacturer		Linde	
	1.2	Model designation		E20 C/P	
	1.2.1	Chassis configuration		4-Wheel	
	1.3	Power unit: battery, diesel, LP gas		36-Volt Battery	48-Volt Battery
	1.4	Operation: manual, pedestrian, rider standing, rider seated, order picker		Rider seated	
	1.5	Load capacity	<i>Q lb</i>	4000	
	1.6	Load center	<i>c in</i>	24	24
	1.8	Load distance (front overhang)	<i>x in</i>	15.4	15.4
	1.9	Wheelbase	<i>y in</i>	61.0	61.0
Weight	2.1	Service weight with min. battery	<i>lb</i>	8827	8827
	2.2	Axle loading with load, front/rear	<i>lb</i>	11433 / 1393	11433 / 1393
	2.3	Axle loading without load, front/rear	<i>lb</i>	4729 / 4097	4729 / 4097
Wheels & Tires	3.1	Tire type - front/rear: cushion, cushion super elastic, pneumatic)		Cushion ¹⁾	Cushion ¹⁾
	3.2	Tire size: front	<i>in</i>	18 x 7 x 12.13	18 x 7 x 12.13
	3.3	Tire size: rear	<i>in</i>	16 x 6 x 10.5'	16 x 6 x 10.5'
	3.5	Wheels: number front/rear (x = driven)		2x / 2	2x / 2
	3.6	Track width, front	<i>b10 in</i>	35.0	35.0
	3.7	Track width, rear	<i>b11 in</i>	31.0	31.0
	Dimensions	4.1	Mast/fork carriage tilt: forward/back	<i>degrees</i>	6° / 5°
4.2		Height of mast lowered	<i>h1 in</i>	See mast table	See mast table
4.3		Free lift	<i>h2 in</i>	See mast table	See mast table
4.4		Lift	<i>h3 in</i>	See mast table	See mast table
4.5		Height of mast extended	<i>h4 in</i>	See mast table	See mast table
4.7		Height of overhead guard/cab	<i>h6 in</i>	80.5 ²⁾	80.5 ²⁾
4.8		Height of seat	<i>h7 in</i>	38.9	38.9
4.12		Height of tow coupling	<i>h10 in</i>	23.0	23.0
4.19		Overall length with 42" forks	<i>l1 in</i>	127.9	127.9
4.20		Length to fork face	<i>l2 in</i>	85.9	85.9
4.21		Overall width	<i>b1/b2 in</i>	42.0 ⁴⁾	42.0 ⁴⁾
4.22		Fork dimensions	<i>s/e/l in</i>	1.5 x 4.0 x 42.0	1.5 x 4.0 x 42.0
4.23		Fork carriage: class		Class II	Class II
4.24		Width of fork carriage	<i>b3 in</i>	38.6	38.6
4.31		Ground clearance under mast, with load	<i>m1 in</i>	2.9	2.9
4.32		Ground clearance, center of wheelbase	<i>m2 in</i>	3.3	3.3
4.33		Aisle width (must add load length and clearance)	<i>Ast in</i>	86 ³⁾	86 ³⁾
4.35	Turning radius	<i>Wa in</i>	70.4	70.4	
Performance	5.1	Travel speed, with/without load	<i>mph</i>	8.7 / 8.7	10 / 10
	5.2	Lifting speed, with/without load	<i>fpm</i>	59 / 89	60 / 102
	5.3	Lowering speed, with/without load	<i>fpm</i>	96 / 78	96 / 78
	5.6	Maximum tractive force, with/without load (5 min. rating)	<i>lbs</i>	2450 / 2450	2200 / 2200
	5.7	Climbing ability, with/without load	<i>%</i>	14 / 22	14 / 22
	5.10	Service brake		Wet disc	Wet disc
Drive	6.1	Drive motor (60 min. rating)	<i>hp</i>	2x 5.4	2x 6.1
	6.2	Lift motor (15% rating)	<i>hp</i>	10.0	13.4
	6.3	Battery voltage	<i>V</i>	36	48
	6.4	Battery compartment dimension (l x w x h; maximum)	<i>in</i>	25.0 x 38.9 x 25.9 ⁵⁾	25.0 x 38.9 x 25.9 ⁵⁾
	6.5	Battery weight (US battery, minimum / maximum)	<i>lb</i>	2155 / 2730	2155 / 2730
Other	8.2	Working pressure for attachments	<i>psi</i>	2465	2465
	8.3	Oil flow for attachments	<i>gpm</i>	8.5	8.5

1) SE tire available

2) Lower OHG available

3) Add length of load plus operating clearance

4) 46" wide with 200/50-10 SE tires

5) Optional battery removal system will reduce compartment height: 23.34 w/battery rollers — 25.40 w/battery slides

Downrating Charts*

E18 346 Series E20 346 Series E20 C/P 346 Series

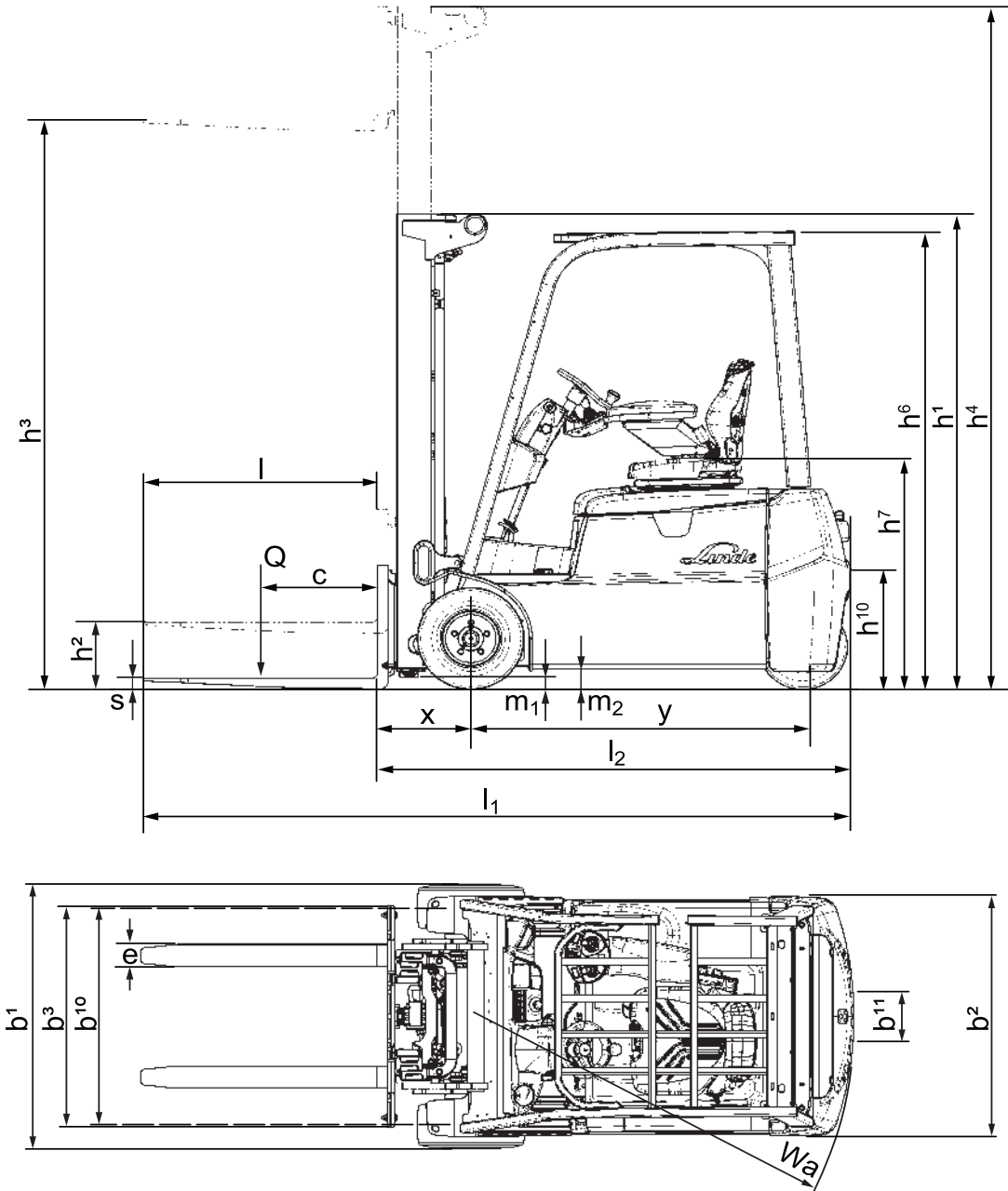
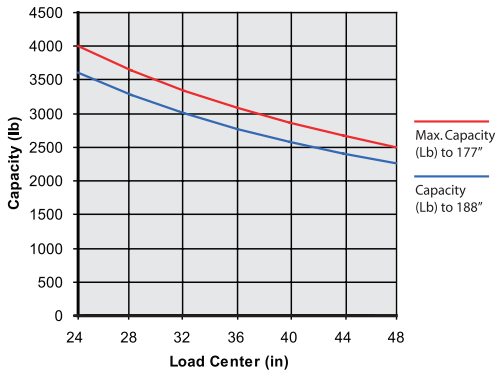
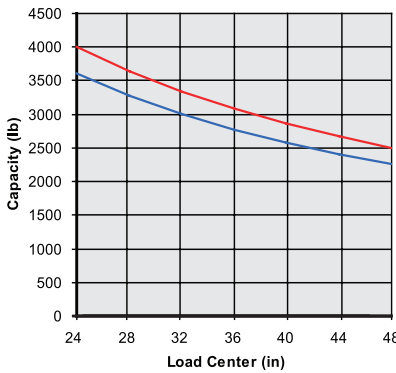
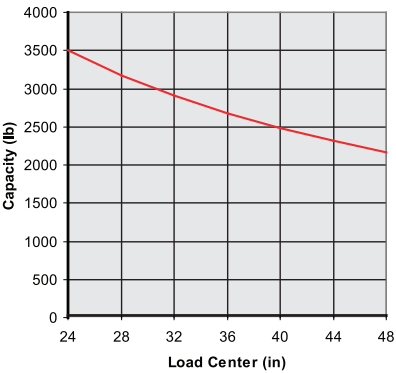

Capacity*

E18

1.5" x 4" x 42" Std. Taper Class II Forks**
 Cushion Tires 18 x 7 x 12.125 Drive Tires**
 Class II Sideshifter • Back Tilt Angle = 5°

Mast Capacity Table

h1	h3	h2	
80.0	122.0	00.0	Simplex
84.0	129.5	00.0	Simplex
91.5	145.5	00.0	Simplex
77.5	168.0	53.0	Triplex
79.5	174.0	55.0	Triplex
84.0	188.0	59.5	Triplex

Capacity (lb) @ 24" Load Center**

Std. Carriage	Integral SS Carriage	Hang-on SS Carriage*
3500	3500	3250
3500	3500	3250
3500	3500	3250
3500	3500	3250
3500	3500	3250
3500	3500	3250

E20

1.5" x 4" x 42" Std. Taper Class II Forks**
 Cushion Tires 18 x 7 x 12.125 Drive Tires**
 Class II Sideshifter • Back Tilt Angle = 5°

Mast Capacity Table

h1	h3	h2	
80.0	122.0	00.0	Simplex
84.0	129.5	00.0	Simplex
91.5	145.5	00.0	Simplex
77.5	168.0	53.0	Triplex
79.5	174.0	55.0	Triplex
84.0	188.0	59.5	Triplex

Capacity (lb) @ 24" Load Center**

Std. Carriage	Integral SS Carriage	Hang-on SS Carriage*
4000	4000	3750
4000	4000	3750
4000	4000	3750
4000	4000	3750
4000	4000	3750
3600	3600	3350

E20 C/P

1.5" x 4" x 42" Std. Taper Class II Forks**
 Cushion Tires 18 x 7 x 12.13 Drive Tires**
 Class II Sideshifter • Back Tilt Angle = 5°

Mast Capacity Table

h1	h3	h2	
80.0	122.0	00.0	Simplex
84.0	129.5	00.0	Simplex
91.5	145.5	00.0	Simplex
77.5	168.0	53.0	Triplex
79.5	174.0	55.0	Triplex
84.0	188.0	59.5	Triplex

Capacity (lb) @ 24" Load Center**

Std. Carriage	Integral SS Carriage	Hang-on SS Carriage*
4000	4000	3750
4000	4000	3750
4000	4000	3750
4000	4000	3750
4000	4000	3750
3600	3600	3350

* For quick reference only, contact factory for detailed ratings. **Capacity ratings can be affected by changing forks, load center, and/or drive tires.

Features

Electrical system

- 36 or 48 volts
- AC technology
- Enclosed motors
- Maintenance free and sealed systems



Linde twin drive pedals

- Quick directional changes
- Short pedal stroke
- No leg fatigue
- Increased productivity
- Precise maneuvering

Energy efficiency

- Excellent heat management
- Energy return system
- Fully programmable performance
- Optimized energy utilization
- Dual AC drive motors
- Limited use of power cables

→ Low maintenance

- Maintenance free multi-disc brakes
- 1000 hour intervals
- Continuous on-board diagnostics

Linde operator compartment

- Ergonomically optimized armrest
- Generous amounts of foot room
- Fully adjustable suspension seat
- Ergonomically designed steering wheel

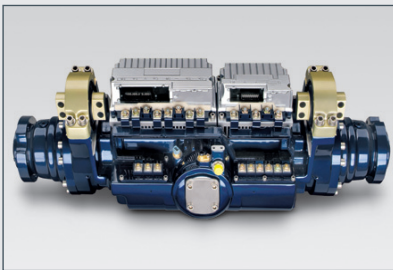

Linde load control

- Safe, precise load handling
- Short hydraulic levers
- Control levers built into the armrest
- On demand power

Productivity

- High uptime
- Fast acceleration
- Quick battery change
- Large battery compartment

Safety

- Quick-set parking brake
- Low-lift side battery removal
- Emergency power disconnect
- "Operator in seat" requirement



Linde Combi-axle (E20 C/P)

- Excellent stability on uneven surfaces
- Aisle width and turning radius similar 3-wheel version
- Exceptional maneuverability in confined areas
- Combined advantage of center pivot and articulating axle



For more information on Linde material handling equipment, please contact:

KION North America Corporation
2450 West 5th North Street, Summerville, SC 29483
Phone: (843) 875-8000 Truck Sales Fax: (843) 875-8471
E-mail: trucksales.na@kiongroup.com
www.kion-na.com

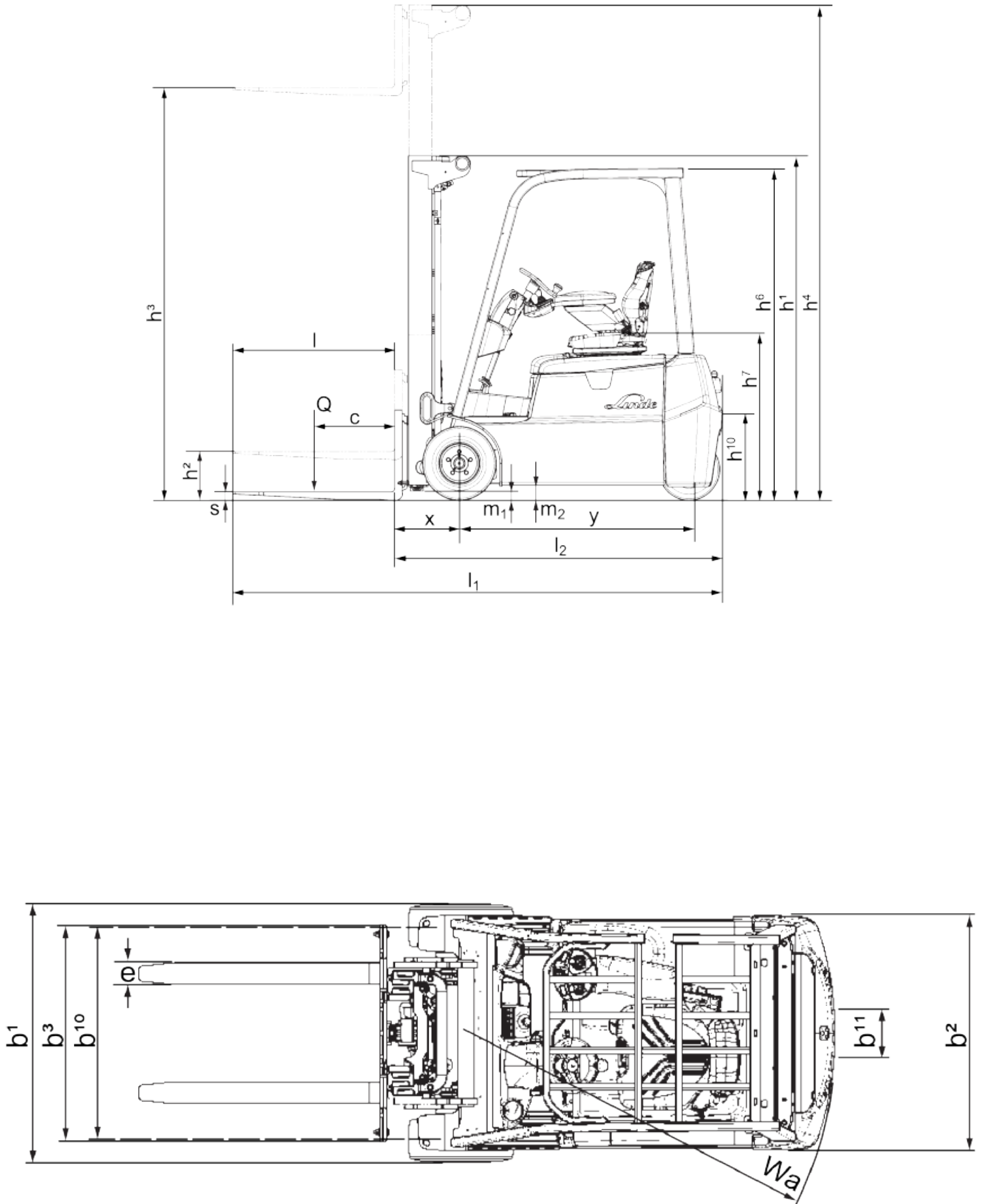

*Refer to Technical Data Chart



ANSI: Standard truck meets all applicable mandatory requirements of ANSI/ISO/BS561 standards for powered industrial trucks.
 NOTE: Performance data may vary due to motor and system efficiency tolerances. The performance depicted represents normal values obtained under typical operating conditions. All metric dimensions are in millimeters unless otherwise specified. All metric dimensions are not direct equivalents due to rounding data. The descriptions and specifications included on this data sheet were in effect at the time of printing. KION North America Corporation reserves the right to make improvements and changes in specification or design without notice and without incurring obligation. Please check with your authorized Linde dealer for information on possible updates or revisions.

For more information on Linde Material Handling equipment, please contact:

TOTAL
WAREHOUSE
 TotalWarehouse.com
 833-868-2500